

## ADL 系列导轨式电能表

# ADL Series DIN-Rail Mounted Electric Energy Meter

安装使用说明书 V1.3

Installation and Operation Instructions V1.3

安科瑞电气股份有限公司

Acrel Electric Co., Ltd.

## 申明

### Statement

版权所有，未经本公司之书面许可，此手册中任何段落、章节内容均不得摘抄、拷贝或以任何形式复制、传播，否则一切后果由违者自负。

All rights reserved. Without the written permission of the Company, any paragraph or section of this manual shall not be extracted, copied or reproduced or distributed in any form. Otherwise, all consequences shall be borne by the violator.

本公司保留一切法律权利。

The Company reserves all legal rights.

本公司保留对本手册所描述之产品规格进行修改的权利，恕不另行通知。订货前，请垂询当地代理商以获悉本产品的当前规格。

Our Company reserves the right to modify the product specifications described in this manual without further notice. Please consult your local agent for the current specifications of this product before placing an order.

修订记录:

Revision history:

日期 date	版本 Version	内容 content
2023.0530	V1.0	初始版本 initial version
2023.0901	V1.1	增加订货说明 Add ordering instructions
2023.9.12	V1.2	修改电压电流接线示意图, 增加保险丝 Modify the voltage and current wiring diagram and add a fuse
2024.04.01	V1.3	1. 增加互感器尺寸 1. Increase the size of the transformer 2. 增加输入电压范围 2. Increase the input voltage range 3. 增加指示灯说明 3. Add indicator light description

# 目 录

## Contents

1 概述.....	1
1 Overview.....	1
2 型号说明.....	1
2 Description of Model.....	1
3 功能列表.....	1
3 List of Functions.....	1
4 技术参数.....	2
4 Technical Parameters.....	2
5 外形尺寸.....	4
5 Overall Dimensions.....	4
6 接线与安装.....	6
6 Connection and Installation.....	7
6.1 电压电流接线示意图.....	7
6.1 Schematic Diagram of Voltage and Current Connection.....	7
6.2 功能性端子.....	9
6.2 Functional Terminal.....	9
7 主要功能特点.....	9
7 Main Functional Features.....	9
7.1 测量功能.....	9
7.1 Measurement Function.....	9
7.2 计量功能.....	10
7.2 Metering Function.....	10
8 操作与显示.....	10
8 Operation and Display.....	10
8.1 按键功能说明.....	10
8.1 Key Function Description.....	10
8.2 显示界面.....	11
8.2 Display Interface.....	11
8.3 编程界面.....	13
8.3 Programming Interface.....	13
8.4 可设置数据项.....	14
8.4 Settable Data Items.....	14
9 通信说明.....	14
9 Communication Instructions.....	14
9.1 地址表.....	15
9.1 Address Table.....	15
10 订货说明 Ordering instructions.....	20

# 1 概述

## 1 Overview

ADL 系列导轨式多功能电能表，是主要针对于光伏并网系统、微逆系统、储能系统、交流耦合系统等新能源发电系统而设计的一款智能仪表，产品具有精度高、体积小、响应速度快、安装方便等优点。具有对电力参数进行采样计量和监测，逆变器或者能量管理系统（EMS）与之进行通讯，根据实时功率及累计电能实现防逆流、调节发电量、电池充放电等功能，可双向计量，实现户用分布式光伏能量管理。

ADL series DIN-rail mounted multifunctional electric energy meter is an intelligent instrument mainly designed for new energy power generation systems such as photovoltaic grid-connected system, micro inverter system, energy storage system, AC coupling system, etc. The product has the advantages of high precision, small volume, high respond speed and convenient installation. The product has the features of sampling, metering and monitoring power parameters, communicating with an inverter or an energy management system (EMS), realizing the functions of preventing reverse flow, regulating power generation, charging and discharging batteries according to real-time power and accumulated electric energy, and realizing bidirectional metering and household distributed photovoltaic energy management.

## 2 型号说明

### 2 Description of Model

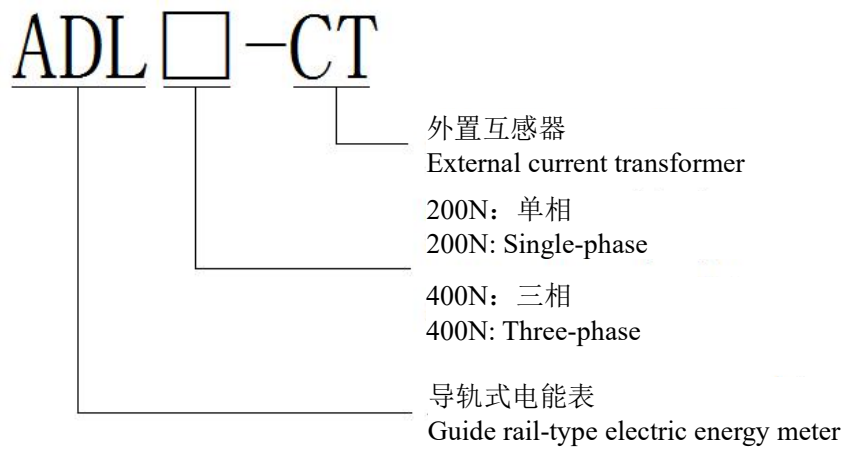

## 3 功能列表

### 3 List of Functions

表 1 功能说明列表

Table 1 List of Function Descriptions

功能 Function	功能说明 Descriptions	ADL200N-CT	ADL400N-CT
电能计量 Electric energy metering	有功电能计量（正、反向） Active energy metering (forward and reverse)	■	■
	无功电能计量（正、反向）	■	■

	Reactive energy metering (forward and reverse)		
	分相电能 Split-phase energy	<input type="checkbox"/>	■
电量测量 Electric quantity measurement	U, I	■	■
	P, Q, S, PF, F	■	■
LCD 显示 LCD display	段式 LCD 显示 Segmented LCD display	■	■
按键编程 Key programming	按键可编程通信、变比等参数 ommunication, transformation ratio and other parameters can be programmable by the key	<input type="checkbox"/>	■
脉冲输出 Pulse output	有功脉冲输出 Active pulse output	■	■
LED 报警 LED alarm	运行指示 Operation instructions	<input type="checkbox"/>	■
通讯 Communication	RS485 接口, 支持 Modbus RTU 规约 RS485: Modbus RTU	■	■

## 4 技术参数

## 4 Technical Parameters

表 2 技术参数说明

Table 2 Description of Technical Parameters

项目 Item		性能参数 Performance Parameters		
型号系列 Model Series		ADL200N-CT	ADL400N-CT	
Measurement 测量	网络 Grid	单相 Single-phase	三相四线、三相三线、单相三线 Three-phase four-wire, three-phase three-wire, single-phase three-wire	
	Voltage 电压	额定电压 Rated voltage	230V	三相: 3×220/380V、3×230/400V、 3×277/480V Three-phase: 3×220/380V、3× 230/400V、3×277/480V
		输入范围 Input Range	±20%	
		过负荷 Overload	1.2 倍额定值 (连续) 1.2 times rating (continuous) 2 倍额定值持续 1 秒 2 times the rating for 1 second	
		功耗 Power consumption	<0.2VA	

		精度等级 Accuracy class	误差±0.5% Error ±0.5%		
	Current 电流	输入电流 Input current	80A, 120A, 200A, 300A	80A, 120A, 200A, 300A, 3×80A, 3×120A, 3×200A, 3×300A	
		过负荷 Overload	1.2 倍额定值 (连续) 1.2 times rating (continuous) 2 倍额定值持续 1 秒 2 times the rating for 1 second		
		功耗 Power consumption	<0.2VA		
		精度等级 Accuracy class	误差±0.5% Error ±0.5%		
		功率 Power	有功、无功、视在功率, 误差±0.5% Active, reactive, apparent power, error ±0.5%		
		电网频率 Grid frequency	45~65Hz, 误差±0.5% 45~65Hz, error ±0.5%		
		响应速率 Response rate	≤100ms (电压、电流、功率) ≤100ms (voltage, current, power)		
	≤1s (电能) ≤1s (electrical energy)				
Metering 计量		电能 Electric energy	有功电能: B级(开口式互感器) Active energy : Class B (split current transformer) 无功电能 (准确度等级 2 级) Reactive energy (Class 2 accuracy)		
electromagnetic compatibility 电磁兼容		静电放电抗扰度 III 级 Electrostatic discharge immunity class III			
		电快速瞬变脉冲群抗扰度 IV 级 Electrical fast transient burst immunity class IV			
		浪涌(冲击)抗扰度 IV 级 Surge (shock) immunity Class IV			
Security 安全性		工频耐压 Power frequency withstand voltage	通信与信号输入之间 AC4kV 1min Between communication and signal input, AC4kV 1min		
		绝缘电阻 Insulation resistance	输入、输出端对机壳>100MΩ Input and output terminals to casing >100MΩ		
Communication 通信		接口与通信规约 Interface and communication protocol	RS485 口、Modbus RTU 规约 RS485 interface and Modbus RTU protocol		
		通信地址范围 Communication address range	Modbus RTU:1~ 247;		
		波特率 Baud rate	支持 1200bps-38400bps Support 1200bps-38400bps		
Environment 环境		工作温度 Operating temperature	-40°C~+70°C		
		储存温度 Storage temperature	-40°C~+70°C		
		相对湿度 Relative humidity	≤95% (无凝露) ≤95% (without condensation)		
		海拔高度 Altitude	≤3000m		

## 5 外形尺寸

### 5 Overall Dimensions

#### 5.1 仪表尺寸

#### 5.1 Instrument Dimensions



图 1 ADL200N-CT

Figure 1 ADL200N-CT

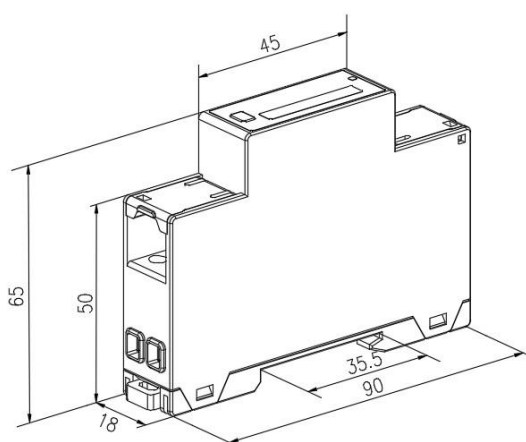

图 2 ADL400N-CT

Figure 2 ADL400N-CT

#### 5.2 互感器尺寸

#### 5.2 Transducer Dimensions

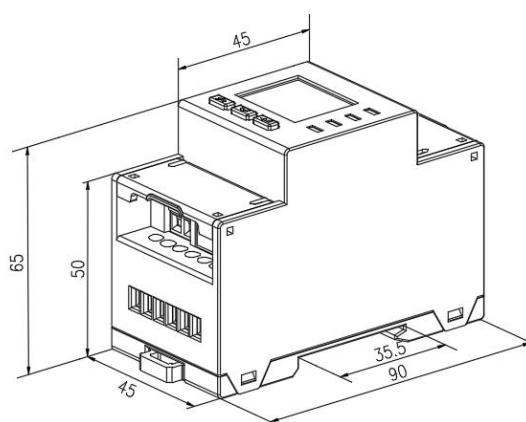
##### 5.2.1 80A/26.6mA 互感器

##### 5.2.1 80A/26.6mA Transformer

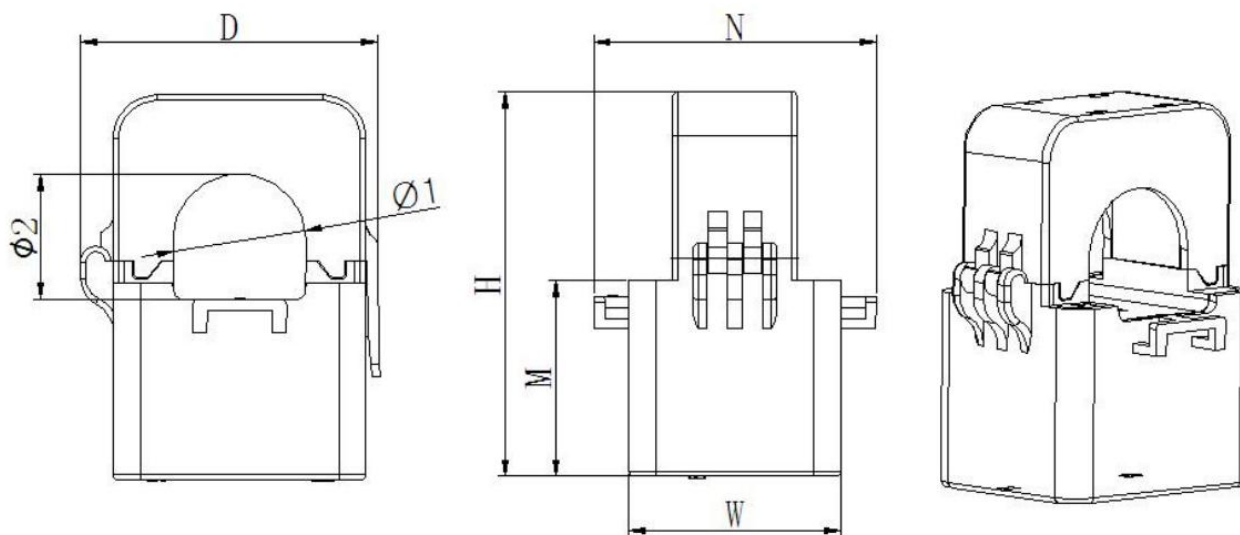



规格 Specification	尺寸 size	外形尺寸 (mm)					穿孔尺寸 (mm)		公差 (mm)
	Specification	Dimensions (mm)					Perforation size (mm)		Tolerance (mm)
		W	H	D	M	N	Φ1	Φ2	
K-Φ10		27	44	32	25	36	10	9	±1

### 5.2.2 120A/40mA 互感器

### 5.2.2 120A/40mA Transformer

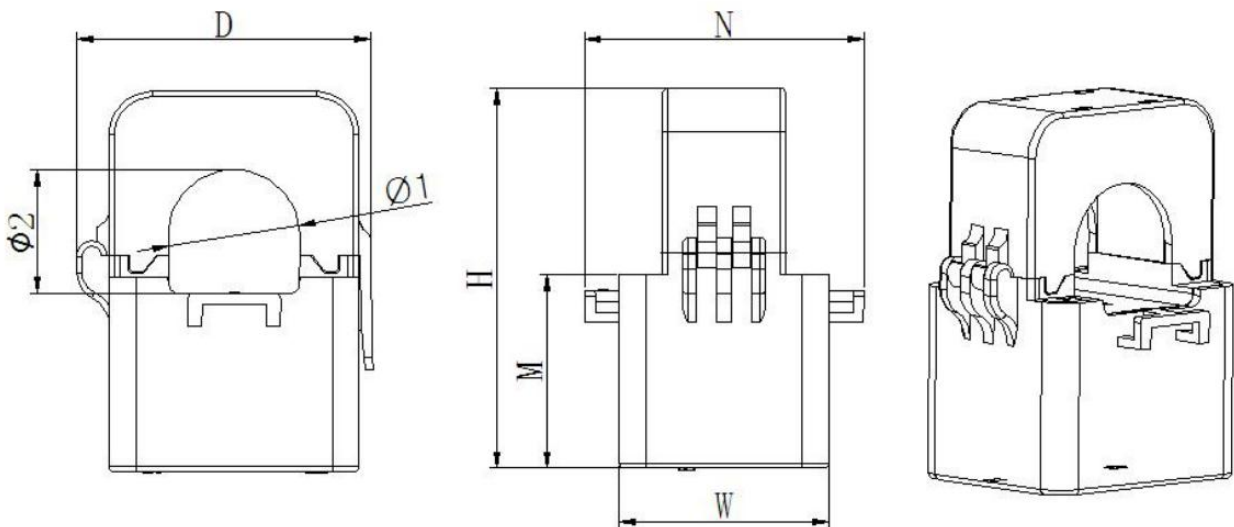

规格 Specification	尺寸 size	外形尺寸 (mm)					穿孔尺寸 (mm)		公差 (mm)
	Specification	Dimensions (mm)					Perforation size (mm)		Tolerance (mm)
		W	H	D	M	N	Φ1	Φ2	
K-Φ16		31	50	36	27	42	16	17	±1

### 5.2.3 200A/66.6mA 互感器

### 5.2.3 200A/66.6mA Transformer

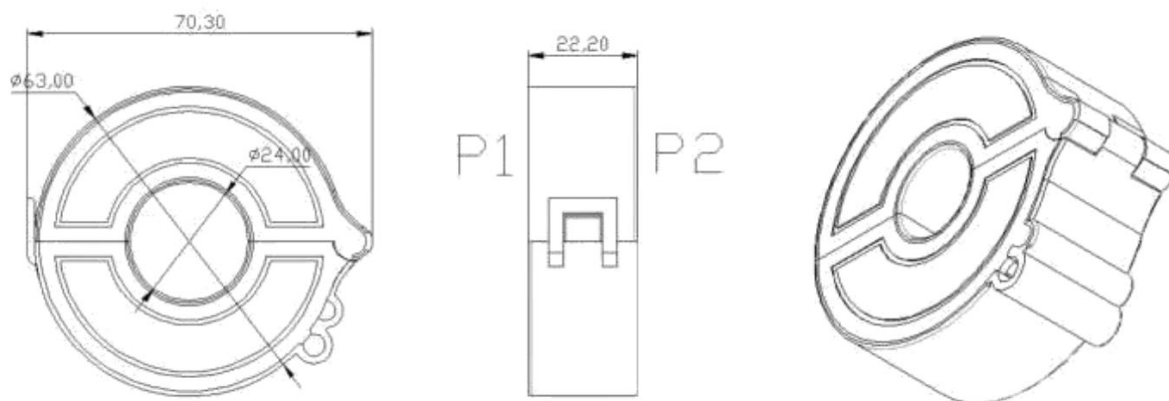

#### 5.2.4 300A/100mA 互感器

#### 5.2.4 300A/100mA Transformer

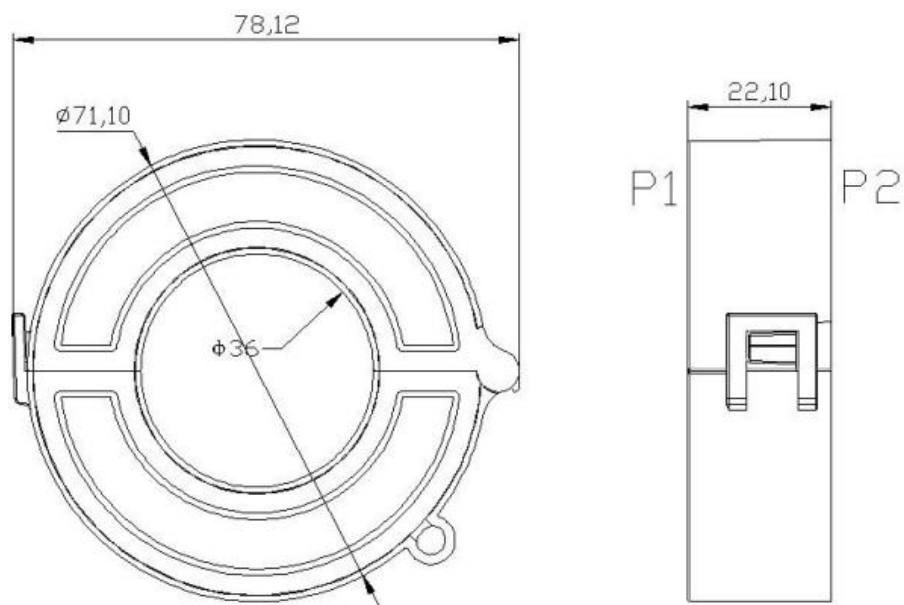

注：互感器二次引出线为 2464 26AWG 单根引出线，标配线长  $2\text{m}\pm 10\text{cm}$ ，并加冷压头。

Note: The secondary leads of the transformer are 2464 26AWG single-strand leads, with a standard wire length of  $2\text{m}\pm 10\text{cm}$ , and equipped with cold-pressed heads.

## 6 接线与安装

## 6 Connection and Installation

### 6.1 电压电流接线示意图

#### 6.1 Schematic Diagram of Voltage and Current Connection



图3 ADL200N-CT  
Figure 3 ADL200N-CT



图4 ADL400N-CT 三相四线经互感器接入  
Figure 4 ADL400N-CT Three-phase Four-wire Connection Through Current Transformer

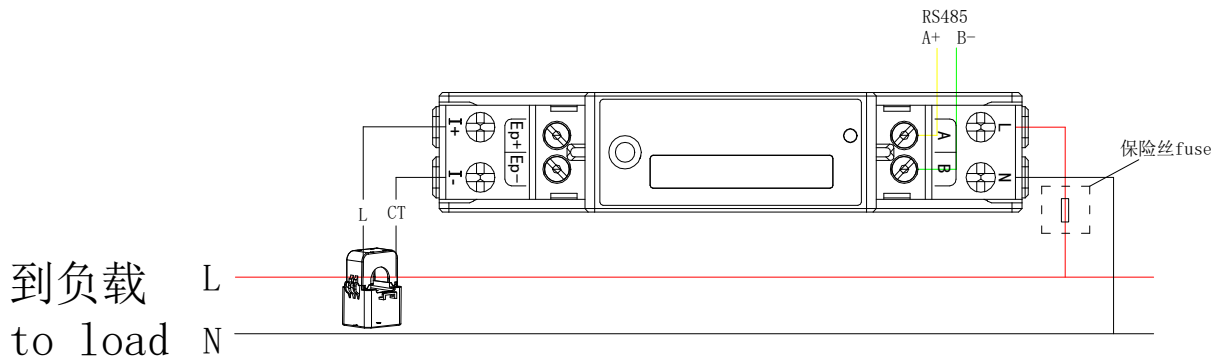

图 5 ADL400N-CT 三相三线经互感器接入（此接法仅限于三项平衡时）（仪表设置为 3P4L）

Figure 5 ADL400N-CT Three-phase Three-wire Connection Through Current Transformer (this connection method is limited to three-phase balance) (instrument is set as 3P4L)

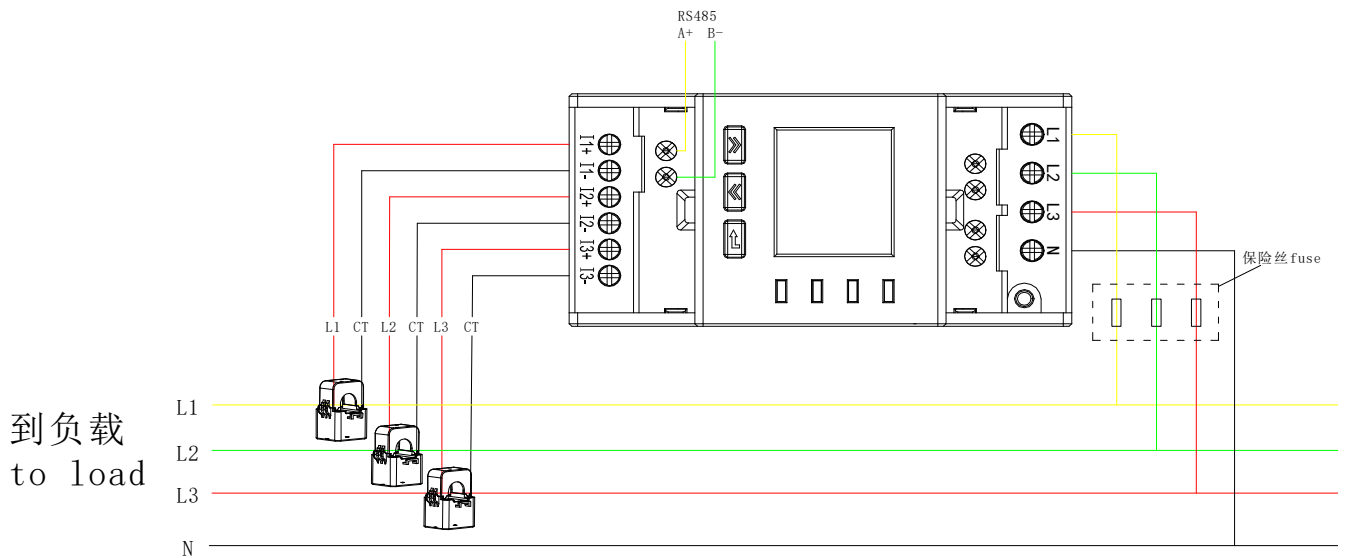

图 6 ADL400N-CT 三相三线经互感器接入（仪表设置为 3P3L）

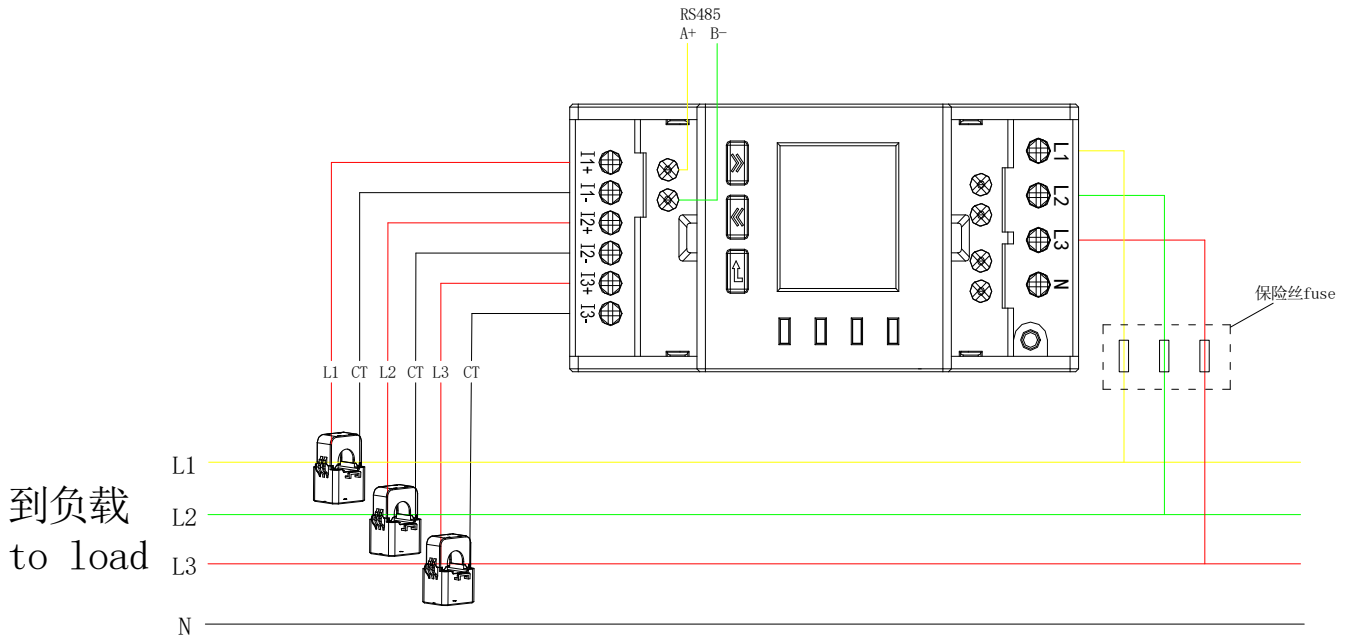
Figure 6 ADL400N-CT Three-phase Three-wire Connection Through Current Transformer (instrument is set as 3P3L)

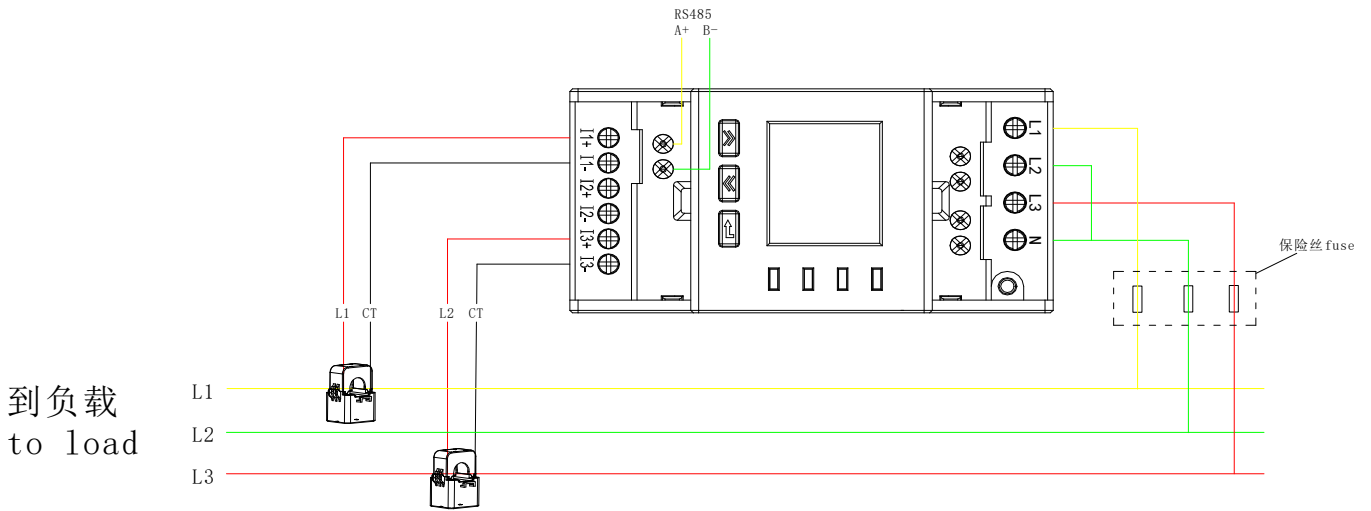

图 7 ADL400N-CT 单相三线经互感器接入

Figure 7 ADL400N-CT Single-phase Three-wire Connection Through Current Transformer

注：出于安全考虑，在电压输入端需接入额定电流 5A 的保险丝。

**Note:**for safty reasons,a fuse with a rated current of 5A needs to be connected to the voltage input terminal.

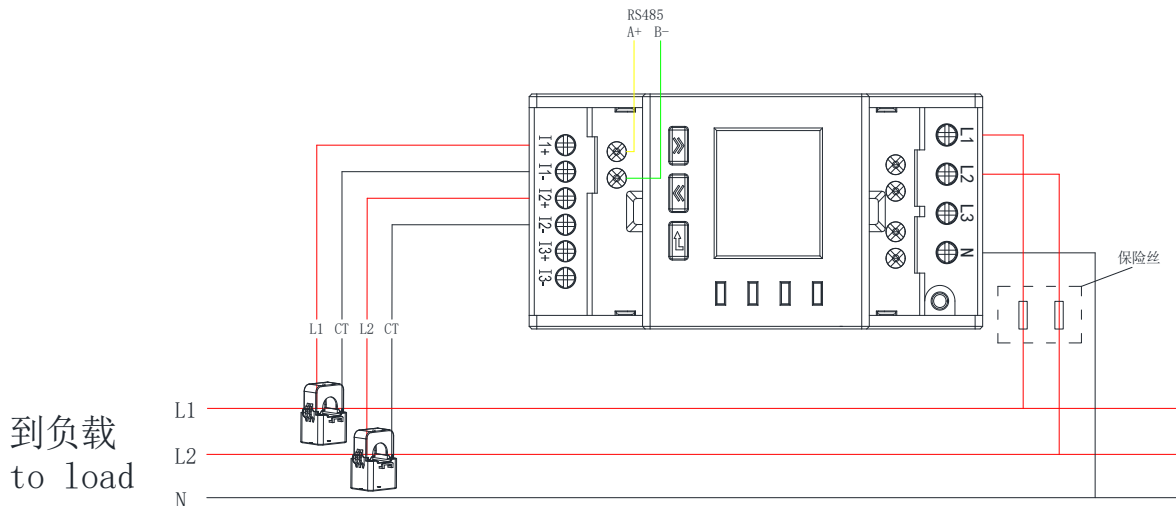
## 6.2 功能性端子

### 6.2 Functional Terminal



图 8 通讯、脉冲接线

Figure 8 Communication and Pulse Connection

## 7 主要功能特点

### 7 Main Functional Features

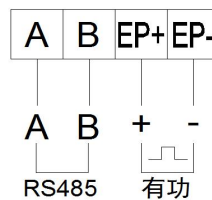
#### 7.1 测量功能

##### 7.1 Measurement Function

能测量全电力参数包括电压 U、电流 I、有功功率 P、<sup>有功</sup> <sub>Active</sub> <sup>AB 相电流</sup> <sub>Phase AB current</sub> 视在功率 S、功率因数 PF、频率。其中电压 U 保留 1 位小数，频率 F 保留 2 位小数，电流 I 保留 2 位小数，功率 P 保留 3 位小数。

It can measure total power parameters including voltage U, current I, active power P, reactive power Q, apparent power S, power factor PF and frequency. Wherein, the voltage U is reserved with 1 decimal place, the frequency F is reserved with 2 decimal places, the current I is reserved with 2 decimal places, and the power P is reserved with 3 decimal places.

如：U = 220.1V, f = 49.98Hz, I = 1.99A, P = 0.439kW

For example,  $U = 220.1V$ ,  $f = 49.98Hz$ ,  $I = 1.99A$ ,  $P = 0.439kW$

仪表同时提供以上电参量高速响应寄存器，见第 9 章通讯说明。

The above electrical parameter high-speed response registers are also provided with the instrument, see Chapter 9 “Communication Instructions”.

## 7.2 计量功能

### 7.2 Metering Function

能计量当前组合有功电能，正向有功电能，反向有功电能，正向无功电能，反向无功电能。

It can measure the current combined active electric energy, forward active electric energy, reverse active electric energy, forward reactive electric energy and reverse reactive electric energy.

## 8 操作与显示

## 8 Operation and Display

### 8.1 按键功能说明

#### 8.1 Key Function Description

表 4 指示灯说明



指示灯名称 Indicator name	说明 illustrate
RUN	运行指示灯，正常运行时按 1HZ 频率闪烁 Operation indicator light flashes at 1HZ frequency during normal operation
COM	正常通讯时闪烁 Flashes during normal communication
STA	预留 reserved
E	脉冲指示灯，如脉冲常数是 600 时，每个脉冲表示 1/600kwh 电量 Pulse indicator light, if the pulse constant is 600, each pulse represents 1/600kwh of electricity

注：ADL200N 只有脉冲灯

Note: ADL200N only has pulse light

表 5 按键功能说明

Table 5 Key Function Description

按键图标 Key Icon	按键名称 Key Name	按键功能 Key Functions
	向上键 Up	向左切换界面 编程界面中左移及闪烁移位 When switching the interface to the left, show left shift and flicker shift in programming interface
	向下键 Down	向右切换界面 编程界面中右移及修改闪烁位 When switching the interface to

		the right, show right shift and modify flicker in programming interface
	编程确定键 Programming confirmation	查看下级菜单 编程界面中确定保存设置 View submenu, confirm the saving setting in the programming interface

## 8.2 显示界面

### 8.2 Display Interface

ADL200N:

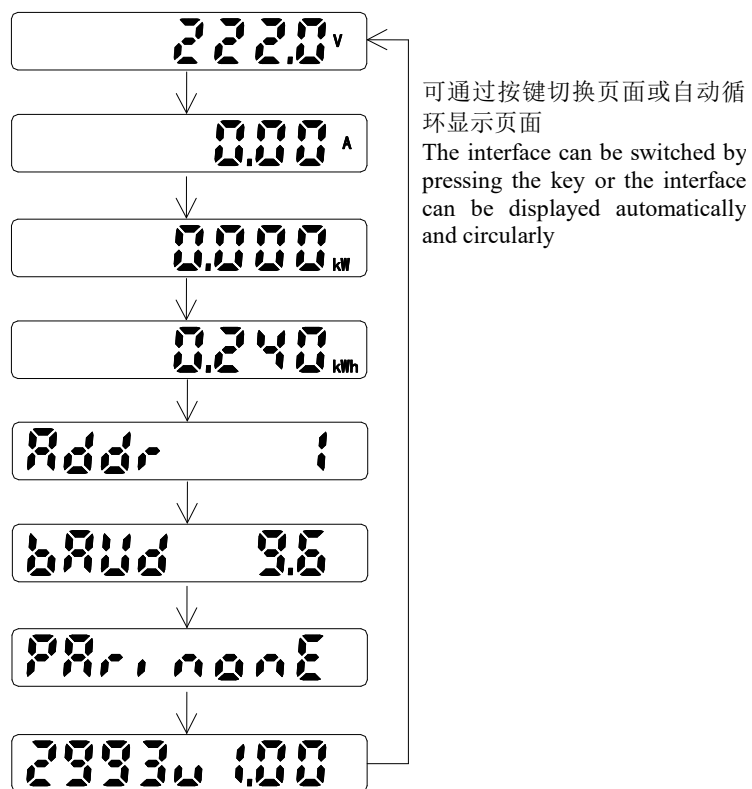

ADL400N:



图 9 显示界面说明

Figure 9 Description of Display Interface





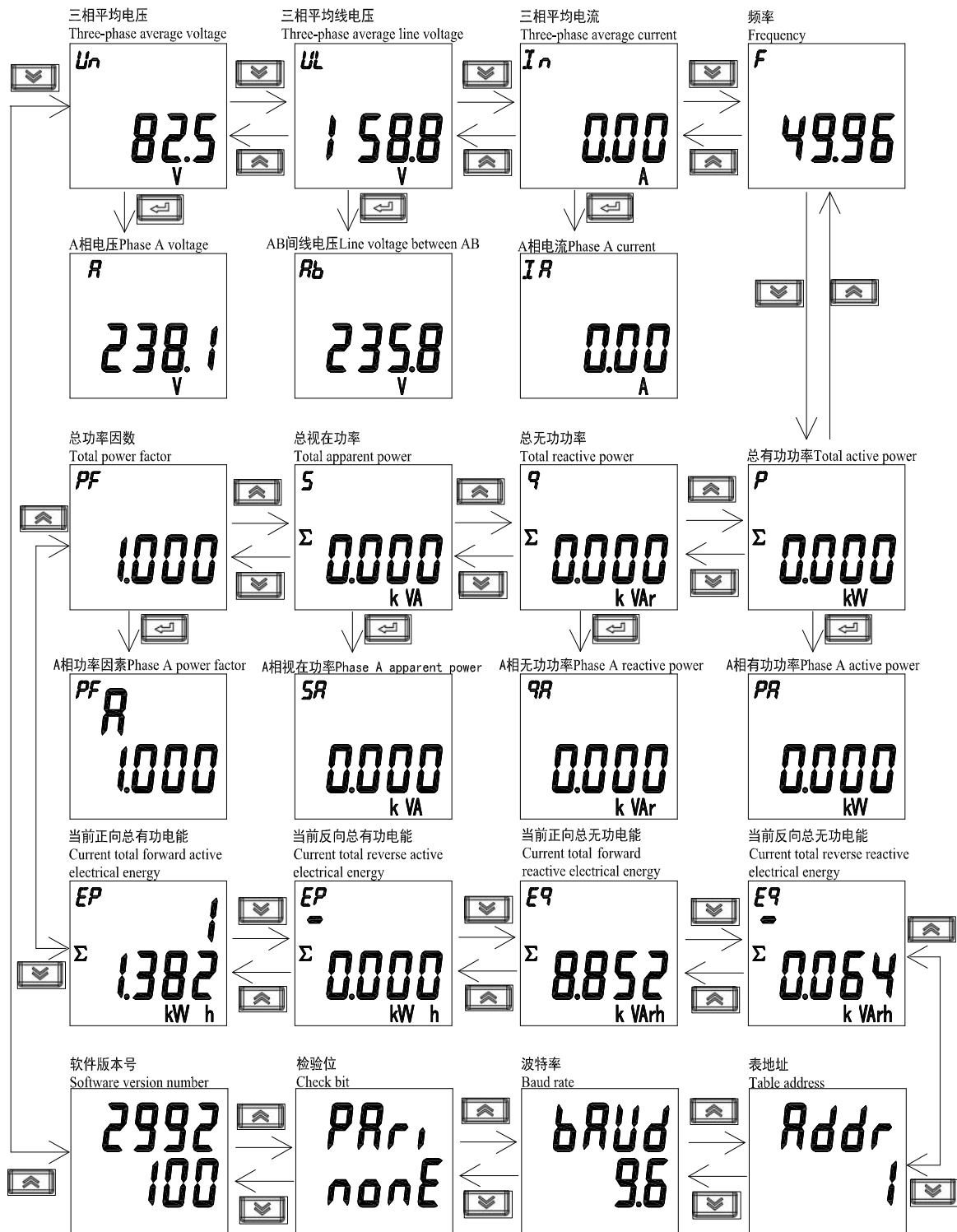

注：以上只是显示界面的一部分，A、B、C相可通过回车键切换（AB间、BC间、AC间同理），其他界面显示模式与上图类似，可根据界面中显示的信息来判断显示含义。









Note: The above is only a part of the display interface. Phase A, B and C can be switched by Enter key (phases between AB, BC and AC are for the same reason). The display mode of other interfaces is similar to that shown in the above figure. The display meaning can be judged according to the information displayed in the interface.

### 8.3 编程界面

### 8.3 Programming Interface

在测量显示菜单中的任一显示项下，长按  可进入“PASS”界面，提示输入密码，默认密码 0001，再按 ，若密码输入错误，则返回“0000”可重新输入；若密码输入正确，则可进行参数设置。设置完成后长按  进入“SAVE”界面，按  键，切换为“YES”后按  则保存并退出，在“no”下按  则不保存直接退出。

When in any display item, press  for a long time to enter the "PASS" interface. There is a prompt for password, and the default password is 0001, and then press  again. If the password is incorrectly entered, return to "0000" to re-enter; If the password is entered correctly, the parameters can be set. Press  for a long time to enter the "SAVE" interface, press  to switch to "YES", then press  to SAVE and exit, and press  when switching to "NO" to exit directly, with no need to "SAVE".

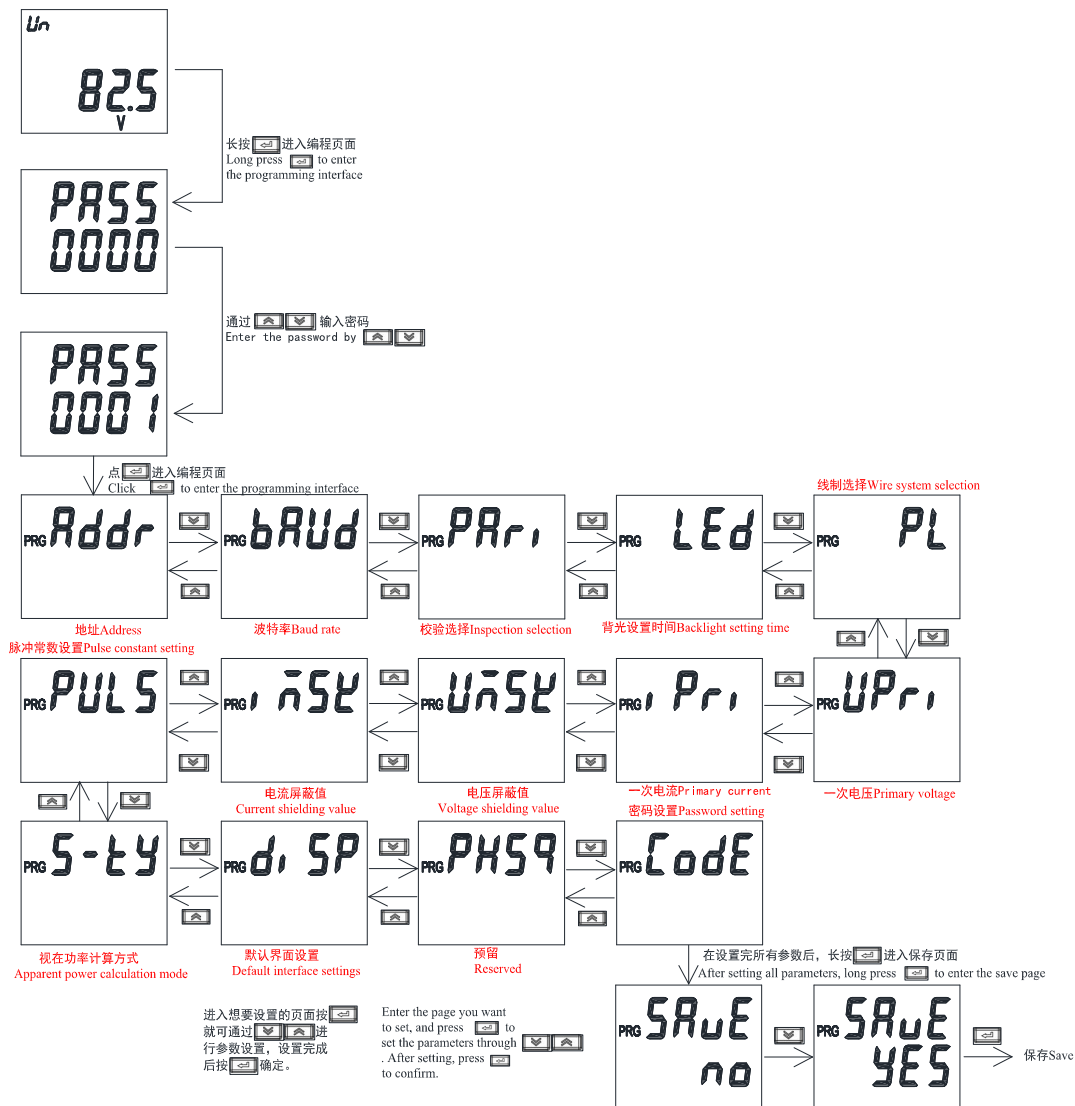

## 8.4 可设置数据项

### 8.4 Settable Data Items

表 7 设置菜单说明

Table 7 Description of Setting Menu

符号 Symbol	含义 Meaning	范围 Scope
Addr	通讯地址设置 slave address	1-247
bAud	波特率选择 Baud rate	38.4: 38400 19.2: 19200 9.6: 9600 4.8: 4800 2.4: 2400 1.2: 1200
PAri	校验选择 parity	None、Even、Odd
LEd	背光时间（预留） Backlight time (reserved)	0-999s
PL	网络选择 Grid	3P4L:三相四线 3P4L: Three-phase four-wire 3P3L:三相三线 3P3L: Three-phase three-wire
UPri	一次电压 Primary voltage	0.1-9999999.9V
iPri	一次电流 Primary current	0.01-999999.99A
UMSK	电压屏蔽值 Voltage shielding value	0-99.99%
iMSK	电流屏蔽值 Current shielding value	0-99.99%
PULS	脉冲常数 Pulse constant	1-99999
S-ty	视在功率计算方式 Apparent power calculation mode	RMS: RMS 计算法 RMS: RMS calculation method PQS: PQS 计算法 PQS: PQS calculation method
diSP	上电默认界面 Power-on default interface	Auto: 自动轮显 Auto: Automatic wheel display 其他: 其他界面 Others: Other interfaces
PHSq	预留 Reserved	
CoDE	密码设置 Password	1-9999

## 9 通信说明

### 9 Communication Instructions

仪表 RS485 通信接口支持 MODBUS-RTU 通信协议,通信口波特率可在 1200bps、2400 bps、4800 bps、9600bps、19200 bps 和 38400 bps 之间设置,校验位为无校验。

The instrument RS485 communication interface supports MODBUS-RTU communication protocol. The baud rate of communication interface can be set between 1,200bps, 2,400 bps, 4,800 bps, 9,600bps, 19,200 bps and 38,400 bps, and the check bit is no check.

仪表的 RS485 通信口要求使用屏蔽双绞线连接,布线时要考虑整个网络的布局:如通信线缆的长度、走向、

上位机的位置、网络末端的匹配电阻、通信转换器、网络可扩展性、网络覆盖范围、环境的电磁干扰情况等因素，都要综合考虑。

The RS485 communication interface of the instrument requires shielded twisted pair connection, and the layout of the whole grid should be considered when wiring: For example, the length and direction of communication cable, the position of upper computer, the matching resistance at the end of the grid, the communication converter, the scalability of the grid, the coverage of the grid, the electromagnetic interference of the environment and other factors should be considered comprehensively.

注：

Note:

- 1、在布线工程上要严格按照要求施工；
1. It shall strictly construct according to the requirements in the wiring project;
- 2、对于暂时不需要通信的仪表都要将他们连接到 RS-485 网络上，以便于诊断和测试；
2. For instruments that do not need communication temporarily, they should be connected to RS-485 grid for diagnosis and test;
- 3、进行 RS-485 电缆连接时，尽量使用双色双绞线，所有的 485 通信口“A”端接同一种颜色，“B”端接另一种颜色。
3. When connecting RS-485 cable, try to use two-color twisted pair. All 485 communication ports "A" are terminated in the same color, and "B" is terminated in another color.
- 4、RS-485 总线(从上位机通信口开始到任一被连接的仪表终端通信口)长不超过 1000 米。
4. The length of RS-485 bus (from the communication interface of the upper computer to any connected instrument terminal communication interface) shall not exceed 1,000 meters.

## 9.1 地址表

### 9.1 Address Table

仪表支持 MODBUS-RTU 协议中的 03H 命令与 10H 命令，03H 为读多个寄存器，10H 为写多个寄存器，协议数据格式请自行查询。下表为仪表的寄存器地址表：

Meter supports 03H command and 10H command in MODBUS-RTU protocol, in which 03H for reading multiple registers and 10H for writing multiple registers. Please check the protocol data format by yourself. The following table is the register address table of the meter:

表 8 通讯地址表

Table 8 Communication Address Table

地址 Address	名称 Name	R/W	字长 Length (Bytes)	类型 Type	单位 Unit	备注 Note
1000H	地址 slave address	R/W	1	uint16		1-247
1001H	波特率 baud rate	R/W	1	uint16		1200, 2400, 4800, 9600, 19200, 38400,
1002H	校验位 parity	R/W	1	uint16		低字节 0: 无校验 None 1: 奇校验 Odd 2: 偶校验 Even 高字节 0: 1 停止位 1stop 1: 1.5 停止位 1.5stop 2: 2 停止位 2stop

1010H	网络选择 Grid	R/W	1	uint16		0:3P4L 1:3P3L
1011H	电压二次额定值 rated second voltage	R/W	1	uint16	0.1V	0.1-999.9V
1012H	电流二次额定值 rated second current	R/W	1	uint16	0.01A	0.01-999.99A
1015H	电压一次额定值 rated primary voltage	R/W	1	uint32	0.1V	0.1-99999.9V
1017H	电流一次额定值 rated primary current	R/W	1	uint32	0.01A	0.01-9999.99A
101DH	密码 Password	R/W	1	uint16		1-9999
101EH	脉冲常数 Pulse constant	R/W	1	uint16		1-99999
101FH	电压屏蔽 Voltage shielding value	R/W	1	uint16	0.01%	
1020H	电流屏蔽 Current shielding value	R/W	1	uint16	0.01%	
1023H	上电默认界面 Power-on default interface	R/W	1	uint16		0: 自动轮显 0: Automatic wheel display 其他: 其他界面 Others: Other interfaces
1035H	视在功率计算方式 Apparent power calculation mode	R/W	1	uint16		0: RMS 1: PQS
2000H	A 相电压 A-phase voltage	R	2	float	V	1.慢速寄存器 1.Slow register 2.ADL200N 只有 A 相数据 2.ADL200N only has A-phase data
2002H	B 相电压 B-phase voltage	R	2	float	V	
2004H	C 相电压 C-phase voltage	R	2	float	V	
2006H	AB 线电压 AB-line voltage	R	2	float	V	
2008H	BC 线电压 BC-line voltage	R	2	float	V	
200AH	CA 线电压 CA-line voltage	R	2	float	V	
200CH	A 相电流 A-phase current	R	2	float	A	
200EH	B 相电流 B-phase current	R	2	float	A	
2010H	C 相电流 C-phase current	R	2	float	A	
2012H	N 线电流 N-phase current	R	2	float	A	
2014H	A 相有功功率 A-phase active power	R	2	float	kW	
2016H	B 相有功功率 B-phase active power	R	2	float	kW	
2018H	C 相有功功率 C-phase active power	R	2	float	kW	
201AH	总有功功率 Total active power	R	2	float	kW	
201CH	A 相无功功率 A-phase reactive power	R	2	float	Kvar	
201EH	B 相无功功率	R	2	float	Kvar	

	B-phase reactive power					
2020H	C 相无功功率 C-phase reactive power	R	2	float	Kvar	
2022H	总无功功率 total reactive power	R	2	float	Kvar	
2024H	A 相视在功率 A-phase apparent power	R	2	float	KVA	
2026H	B 相视在功率 B-phase apparent power	R	2	float	KVA	
2028H	C 相视在功率 C-phase apparent power	R	2	float	KVA	
202AH	总视在功率 Total apparent power	R	2	float	KVA	
202CH	A 相功率因数 A-phase power factor	R	2	float		
202EH	B 相功率因数 B-phase power factor	R	2	float		
2030H	C 相功率因数 C-phase power factor	R	2	float		
2032H	总功率因数 Total power factor	R	2	float		
2034H	频率 Frequency	R	2	float	Hz	
2100H	A 相电压 A-phase voltage	R	2	float	V	
2102H	B 相电压 B-phase voltage	R	2	float	V	
2104H	C 相电压 C-phase voltage	R	2	float	V	
2106H	AB 线电压 AB-line voltage	R	2	float	V	
2108H	BC 线电压 BC-line voltage	R	2	float	V	
210AH	CA 线电压 CA-line voltage	R	2	float	V	
210CH	A 相电流 A-phase current	R	2	float	A	
210EH	B 相电流 B-phase current	R	2	float	A	
2110H	C 相电流 C-phase current	R	2	float	A	
2112H	N 线电流 N-phase current	R	2	float	A	
2114H	A 相有功功率 A-phase active power	R	2	float	kW	
2116H	B 相有功功率 B-phase active power	R	2	float	kW	
2118H	C 相有功功率 C-phase active power	R	2	float	kW	
211AH	总有功功率 Total active power	R	2	float	kW	
211CH	A 相无功功率 A-phase reactive power	R	2	float	Kvar	
211EH	B 相无功功率 B-phase reactive power	R	2	float	Kvar	

1.快速寄存器  
(响应时间≤100ms)  
1.Slow register  
(response rate ≤100ms)

2.ADL200N 只有 A 相数据  
2.ADL200N only has A-phase data

2120H	C相无功功率 C-phase reactive power	R	2	float	Kvar	
2122H	总无功功率 total reactive power	R	2	float	Kvar	
2124H	A相视在功率 A-phase apparent power	R	2	float	KVA	
2126H	B相视在功率 B-phase apparent power	R	2	float	KVA	
2128H	C相视在功率 C-phase apparent power	R	2	float	KVA	
212AH	总视在功率 Total apparent power	R	2	float	KVA	
212CH	A相功率因数 A-phase power factor	R	2	float		
212EH	B相功率因数 B-phase power factor	R	2	float		
2130H	C相功率因数 C-phase power factor	R	2	float		
2132H	总功率因数 Total power factor	R	2	float		
2134H	频率 Frequency	R	2	float	Hz	
3000H	总有功电能一次值 active electric energy	R	4	double	kWh	
3004H	正向有功电能一次值 forward active electric energy	R	4	double	kWh	
3008H	反向电能一次值 reverse active electric energy	R	4	double	kWh	
300CH	总无功电能一次值 reactive electric energy	R	4	double	kVarh	
3010H	正向无功电能一次值 forward reactive electric energy	R	4	double	kVarh	
3014H	反向无功电能一次值 reverse reactive electric energy	R	4	double	kVarh	
3018H	视在电能一次值 apparent electric energy	R	4	double	kVAh	
301CH	A相总有功电能一次值 active electric energy of phase A	R	4	double	kWh	
3020H	A相正向有功电能一次值 forward active electric energy of phase A	R	4	double	kWh	
3024H	A相反向有功电能一次值 reverse active electric energy of phase A	R	4	double	kWh	
3028H	A相无功电能一次值	R	4	double	kVarh	

	reactive electric energy of phase A					
302CH	A 相正向无功电能一次值 forward reactive electric energy of phase A	R	4	double	kVarh	
3030H	A 相反向无功电能一次值 reverse reactive electric energy of phase A	R	4	double	kVarh	
3034H	B 相总有功电能一次值 active electric energy of phase B	R	4	double	kWh	
3038H	B 相正向有功电能一次值 forward active electric energy of phase B	R	4	double	kWh	
303CH	B 相反向有功电能一次值 reverse active electric energy of phase B	R	4	double	kWh	
3040H	B 相无功电能一次值 reactive electric energy of phase B	R	4	double	kVarh	
3044H	B 相正向无功电能一次值 forward reactive electric energy of phase B	R	4	double	kVarh	
3048H	B 相反向无功电能一次值 reverse reactive electric energy of phase B	R	4	double	kVarh	
304CH	C 相总有功电能一次值 active electric energy of phase C	R	4	double	kWh	
3050H	C 相正向有功电能一次值 forward active electric energy of phase C	R	4	double	kWh	
3054H	C 相反向有功电能一次值 reverse active electric energy of phase C	R	4	double	kWh	
3058H	C 相无功电能一次值 reactive electric energy of phase C	R	4	double	kVarh	
305CH	C 相正向无功电能一次值 forward reactive electric energy of phase C	R	4	double	kVarh	
3060H	C 相反向无功电能一次值 reverse reactive electric energy of phase C	R	4	double	kVarh	

## 10 订货说明 Ordering instructions

订货规格 Ordering specifications	电流互感器参数 Current transformer parameters	互感器数量 Number of transformers	备注 Notes
ADL200N-CT/D10	80A/26.6mA	1	
ADL200N-CT/D16	120A/40mA	1	
ADL200N-CT/D24	200A/66.6mA	1	
ADL200N-CT/D36	300A/100mA	1	
ADL400N-CT/D10	80A/26.6mA	3	
ADL400N-CT/D16	120A/40mA	3	
ADL400N-CT/D24	200A/66.6mA	3	
ADL400N-CT/D36	300A/100mA	3	



总部：安科瑞电气股份有限公司

Headquarter: Acrel Co., LTD.

地址：上海市嘉定区育绿路 253 号

Address: No.253 Yulv Road Jiading District, Shanghai, China

电话：0086-21-69158338 0086-21-69156052 0086-21-59156392 0086-21-69156971

TEL.: 0086-21-69158338 0086-21-69156052 0086-21-59156392 0086-21-69156971

传真：0086-21-69158303

Fax: 0086-21-69158303

网址：www.acrel-electric.com

Web-site: www.acrel-electric.com

邮箱：ACREL008@vip.163.com

Email: ACREL008@vip.163.com

邮编：201801

Postcode: 201801

生产基地：江苏安科瑞电器制造有限公司

Manufacturer: Jiangsu Acrel Electrical Manufacturing Co., LTD.

地址：江苏省江阴市南闸街道东盟工业园区东盟路 5 号

Address: No.5 Dongmeng Road, Dongmeng industrial Park, Nanzha Street, Jiangyin City, Jiangsu Province, China

电话：0086-510-86179966

TEL: 0086-510-86179966

传真：0086-510-86179975

Fax: 0086-510-86179975

网址：www.jsacrel.com

Web-site: www.jsacrel.com

邮箱：sales@email.acrel.cn

Email: sales@email.acrel.cn

邮编：214405

Postcode: 214405